

**UCC3889 Bias Supply Controller Evaluation Kit
– Schematic and Lists of Materials**

by Bill Andreycak

Evaluation Kits facilitate a quick measurement of new IC performance in typical application circuits without a lengthy investment of time and resources. The schematic for the UCC3889 Off-Line Bias Supply Controller IC Evaluation Kit is shown below in Figure 1 with a photograph of the top side layout in Figure 2. Notice that this board is designed to accept both conventional "through-hole" or leaded components as

well as their surface mount counterparts. An additional prototyping area allows engineers to further customize these units to address their projects' specific needs. Component lists for two popular 1 Watt (output power) applications are also provided, and complete design details are available in Unitrode Application Note U-149: "Elegantly Simple Off-Line Bias Supply for Very Low Power Applications".

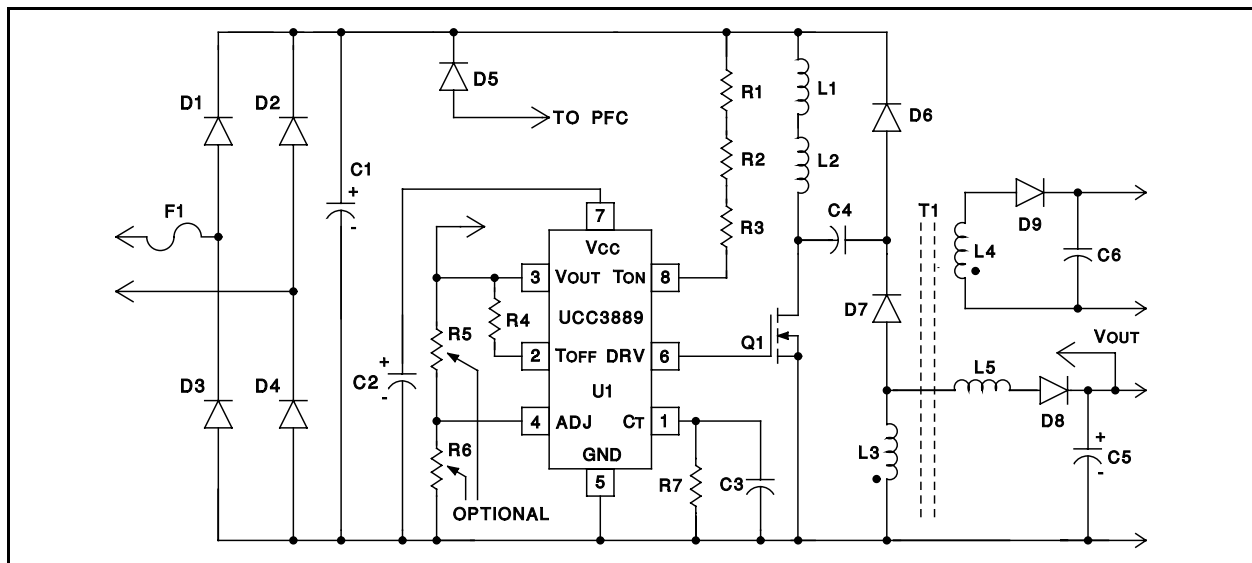

Figure 1. UCC3889 Evaluation Kit Schematic

**Nonisolated 85 to 265VAC Universal Input,
12VDC / 1 Watt Converter**

- C1 = 2.2 μ F/450 VDC Electrolytic
- C2 = 2.2 μ F/35 VDC Electrolytic
- C3 = 150pF/16 VDC Ceramic Disc
- C4 = 0.1 μ F/100 VDC Polyester foil
- C5 = 33 μ F/25VDC Electrolytic (low ESR)
- D1-D4 = 1A/800V Rectifier (1N4006)
- D6,D7 = 1A/600V Fast Recovery Rectifier (1N4937)
- D8 = 1A/200VDC Fast Recovery Rectifier (1N4935)
- F1 = 0.2 ADC/250VAC Fuse
- L1,L2 = 1mH (each) Inductor, 200 mA peak, 250 VDC rating
- L3 = 390 μ H Inductor, 250mA peak

- L5 = Jumper Wire, AWG#20 (short circuit)
- Q1 = 600V/2A MOSFET, (MTP1N60 or IRFBC10)
- R1,2,3 = 110k, 1/2W, 5%, 150VDC rating each (three used)
- R4 = 150k, 1/4W, 5%
- R7 = 2 Meg, 1/4W, 5%
- U1 = UCC3889 Control IC

Components **NOT USED** in this design:
C6, D5, D9, L4, R5, R6

Optional component list:

- D5 = 1A/800V DIODE (1N4006) - used with DC input from PFC or UPS
- R5,R6 = 1/4W, 5% resistors - used to program other output voltages

Transformer Isolated 85 to 265VAC Universal Input, 12VDC / 1 Watt Converter

- C1 = 2.2 μ F/450 VDC Electrolytic
 C2 = 1 μ F/35 VDC Electrolytic
 C3 = 150pF/16 VDC Ceramic
 C4 = 0.1 μ F/150 VDC Polyester foil
 C5,6 = 33 μ F/25VDC Electrolytic (low ESR)
 D1-4 = 1A/800V Rectifier (1N4006)
 D6,7 = 1A/600V Fast Recovery Rectifier (1N4937)
 D8,9 = 1A/200VDC Fast Recovery Rectifier (1N4935)
 F1 = 0.2ADC/250VAC Fuse
 L1,2 = 1mH (each) Inductor, 200mA peak, 250VDC rating
 L4 = Transformer; 1:1 Turns ratio, 300 μ H (Coilcraft # E3497A)
 L5 = 10 μ H, 750mA peak
 Q1 = 600V/2A MOSFET, (MTP1N60 or IRFBC10)
 R1,2,3 = 110k, 1/2W, 5%, 150VDC rating each (three used)
 R4 = 150k, 1/4W, 5%
 R7 = 2 Meg, 1/4W, 5%
 U1 = UCC3889 CONTROL IC

Components **NOT USED** in this design:
D5, L3, R5, R6

Optional component list:

- D5 = 1A/800V DIODE (1N4006) - used with DC input from PFC or UPS
 R5,R6 = 1/4W, 5% resistors - used to program other output voltages

Note that the control technique and cascade Flyback configuration used in these examples can be extended to higher power levels and a variety of applications. This is accomplished by selecting the converter's power components accordingly. Higher current ratings for the power MOSFET, rectifiers and inductors, along with lower inductance values are usually all that's required. Other topologies, for example, the simple (non-cascaded) flyback, forward and boost converters can be controlled by the UCC3889 IC. Many distributed DC power and DC to DC converters make likely candidates for this control technique. Power Factor Correction (PFC) can also be achieved with this IC when used in a discontinuous inductor current boost configuration. Consult Unitrode Application Note U-132 for information on the controlled on-time, variable off-time PFC control technique which can be implemented with the UCC3889 without the need for current sensing. For further information, contact a local Unitrode representative or Field Application Engineer.

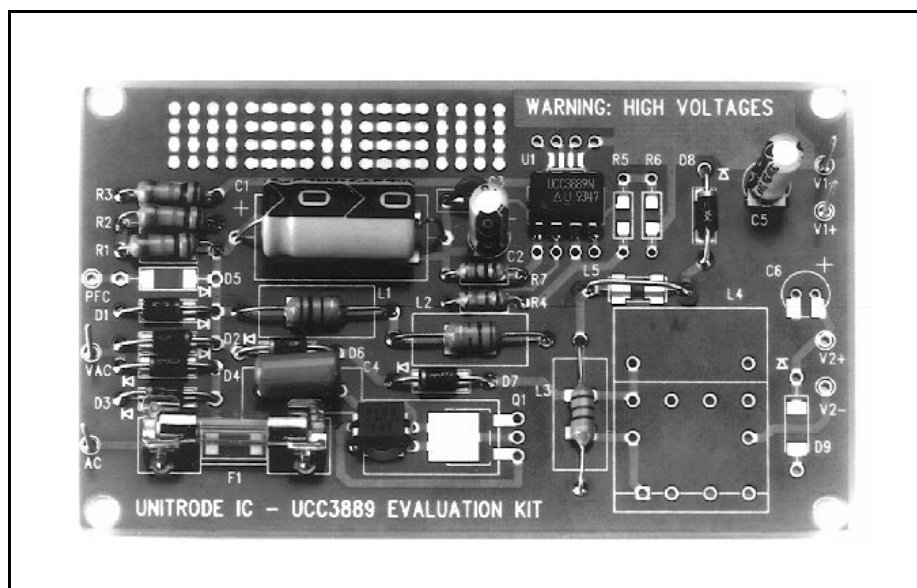

Figure 2. Top Side PC Board Photo